



FAG



Bearing Supports for Agricultural Engineering

Low-maintenance – Weatherproof – Economical

Sophisticated and Economical: Bearing Technology with Comprehensive Service

Decades of experience in agricultural engineering means that our product range has literally “matured”. Schaeffler Group engineers are very familiar with the requirements of this sector and also the high demands involved in increasing productivity. This is why they develop bearing supports that the user really needs, be it for sowing in the spring during torrential rain or for harvesting in hot, dusty conditions.

[Here are some advantages of INA and FAG bearings for agricultural machinery](#)

- Insensitive to constant vibrations and high shocks
- Reliable operation in every kind of weather, for example due to a carefully considered and sophisticated seal concept
- Often low maintenance or even maintenance free, ensuring high machine availability
- Easy to fit and often available as complete units
- Sometimes unconventional, but astonishingly simple.

[Our range of services for agricultural engineering:](#)

- Expert personal consultation during all phases of the product lifecycle
- **medias**[®] product selection and information system
- BEARINX[®] calculation service
- FEM analysis and dynamic simulations
- Measurements at the customer’s premises and testing of customer samples on Schaeffler Group test stands
- Tribology
- Special materials and surface coatings.

Our expertise is your benefit. Benefit from our range of products. We’d be happy to advise you.



Bearings for tillage and sowing Pages 4 – 7



Applications in tractors Pages 8 – 9



Products for harvesting machines Pages 10 – 13



Engineering & service Page 14

Easy to Fit and Often Maintenance-free: Bearing Systems for Tillage Machines and Seeders



Bearing supports in agricultural engineering must be reliable and capable of supporting heavy loads, such as for supporting metering units in seeders (Photo: Jumil)

Agricultural engineering involves a wide range of machines, equipment and implements. This ranges from tillage machines, tractors, tedders and balers to powerful harvesting equipment such as forage harvesters or combine harvesters. Even if the machines are very different, the operating conditions are always harsh. In summer, dust and sand place high demands on the

bearing seals, whereas during the spring and fall, moisture is a real challenge for farmers. Heavy soils test the mechanical strength of all machine parts to the limit. Constant vibrations and high shocks are loads that occur throughout the entire year. This is why the bearing supports in tillage machines have to be particularly robust.

Here, bearings are often combined with flanged housings that simplify assembly. One example are plow discs, the inclined position of which results in transverse forces and bending moments as well as radial loads.

A Clever Bearing Solution for Changing Plow Discs Quickly

The Schaeffler Group's application engineers have developed an innovative system solution for the heavy bearing supports in plow discs. These bearing supports only have to be screwed onto the plow disc and the machine frame. This means that it takes only a few minutes to change the plow discs. The unit is also maintenance-free.

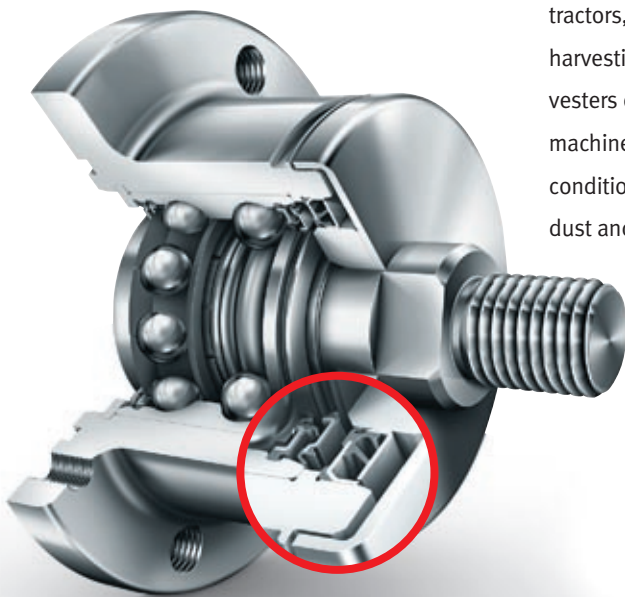

A customer-friendly special solution: Maintenance-free plow disc bearing support



It consists of:

- a double-row angular contact ball bearing from our range of wheel bearings for automotive applications – capable of supporting heavy loads, with high tilting rigidity and double seals on both sides,
- a machined housing with anti-corrosion protection,
- an integrated threaded pin including locating surfaces,
- a protective washer.

An additional high-performance three lipped cassette seal is located on the side subjected to contamination. Two grease reservoirs located between the seals ensure that the seal lips are permanently lubricated and therefore prevent dry running.

The bearing system operates clearance-free after fitting.

Compact Bearing Units for Seed Discs

This angular contact needle roller bearing unit (picture on right) offers manufacturers of agricultural equipment a maintenance-free system where the seed disc only needs to be screwed on.

The angular contact needle roller principle means that high torques and axial loads can be supported. The units are clearance-free, are supplied with the maximum grease quantity, and the extremely effective cassette seals with several seal lips facilitate operation without maintenance and downtimes. The seed disc can be changed quickly and without any problems by simply loosening the screws.

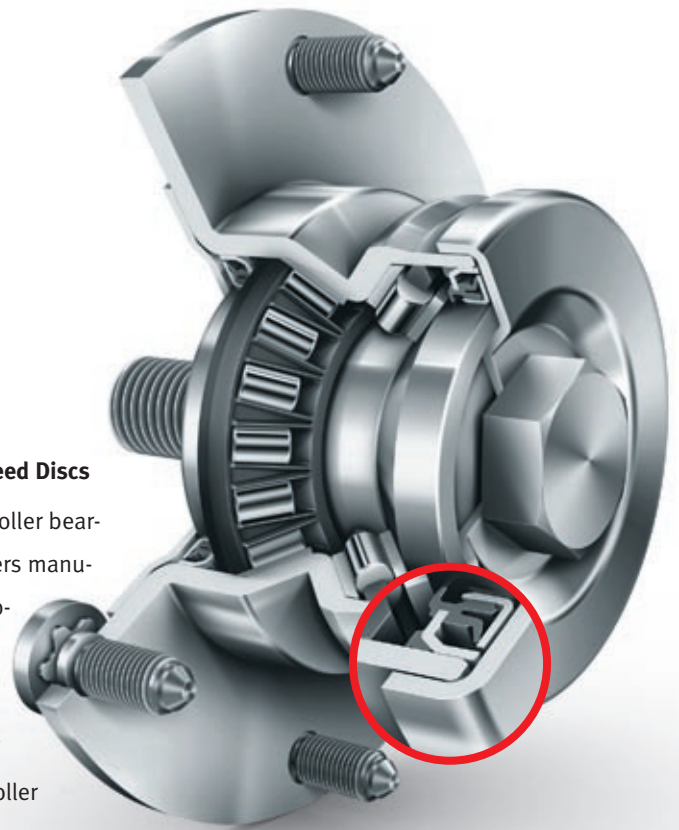

Extremely effective seals: Flanged housing unit with multi-lip cassette seal for the bearing supports in seed discs

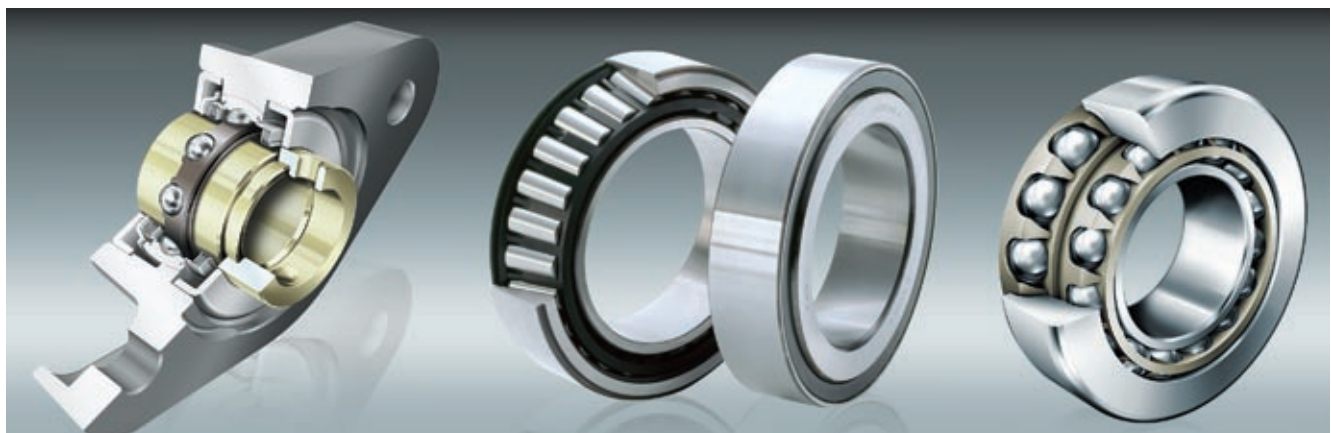

Perfect for tillage: Radial insert ball bearing unit with special seals for protection against shocks and contamination, sealed tapered roller bearing and double-row angular contact ball bearing from FAG's comprehensive range of products

Innovations That are Worthwhile: Individual Solutions...



Rolling bearings as a cost-reduction factor: Seeders are more cost-effective with durable and low-maintenance system solutions from INA

the perfect development partner for bearing positions that are subjected to demanding conditions of this sort. One example of this is our compact four-point contact ball bearing specially developed for seed discs, which has proven itself in operation close to the soil.

Four Advantages of the Four-Point Contact Ball Bearing

- High tilting rigidity
- High load carrying capacity
- Clearance-free operation
- Optimized three-lip seals, which ensure maintenance-free operation of the bearing position with the maximum grease quantity.

One of the seal lips of this seal is arranged in a radial direction on the ground surface of the inner ring, which is protected against corrosion. The other two seal lips are arranged in an axial direction on a protective washer that is pressed on the inner ring. The machined protective washer with anti-corrosion protection is positioned in such a way that a defined gap (labyrinth) is created between the washer and the outer ring. This has the advantage that the seal lips offer excellent protection against damage. This also means that space for an outer grease chamber filled with barrier grease is created.

Naturally, Maintenance-free!

A Seed Disc Bearing Support from INA

More than 100 seed disc bearings can be found in a seeder, depending on the width of the machine. Relubricating these bearings would be an impossible task during the season. The ambient conditions are harsh, for example, fine, abrasive dust particles, aggressive acidic silage effluent, and heavy stony clay soil. This is clearly not a suitable environment for a standard bearing.

That's why a special bearing solution is required – with a particularly effective seal concept. The Schaeffler Group is

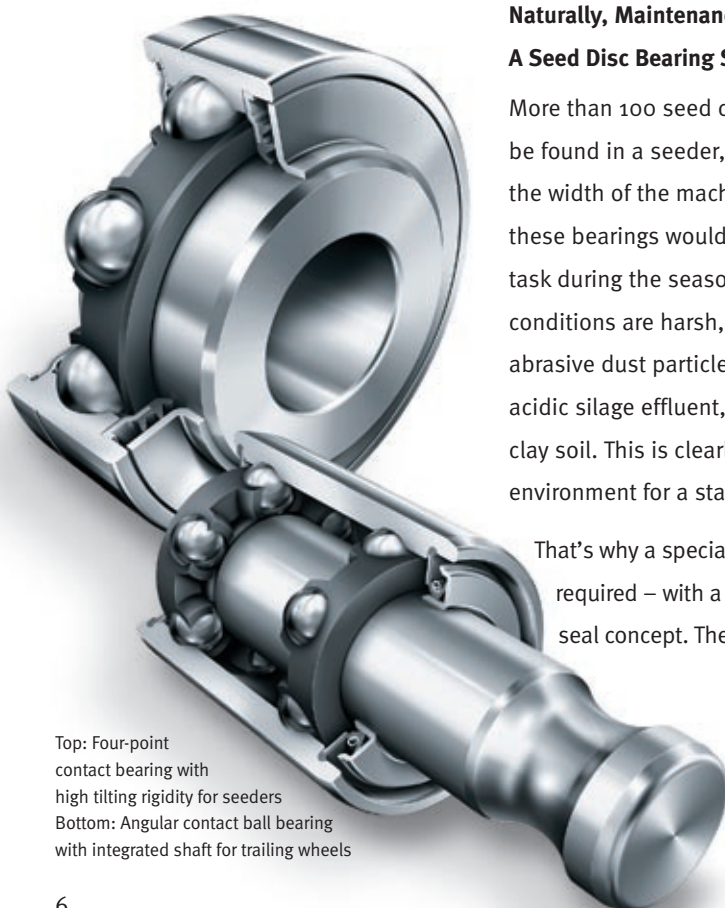

Top: Four-point contact bearing with high tilting rigidity for seeders
Bottom: Angular contact ball bearing with integrated shaft for trailing wheels

... and a High-Performance Standard Range

Shorten Assembly Times!

A Bearing Unit for Trailing Wheels.

We have a bearing unit that considerably simplifies the design of your seeder (picture on page 6 below left), namely a double-row angular contact ball bearing with an integrated pin. This unit is well-known and proven in the automotive sector and it has undergone further development for agricultural engineering applications. Conclusion: This unit considerably reduces the assembly times for trailing wheels.

The perfectly-designed seals mean that the bearing has a significantly longer operating life than its competitors, even in harsh operating conditions. The large grease reservoir does away with the need for any maintenance. For the customer, this means no downtimes for repairs, the wheels do not need to be changed prematurely, leading to lower costs.

This is just one special solution of many that we would like to discuss with you.

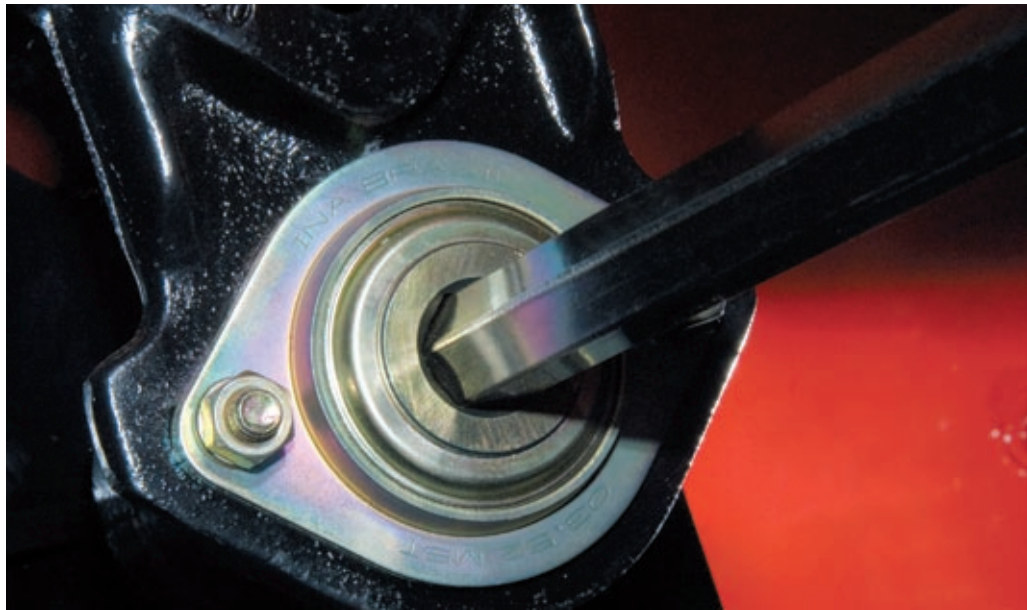

2-hole flange unit: Bearing with hexagonal bore and flinger shield in a seeder

Always Available – The Standard Range

INA and FAG have a total of nearly 40,000 volume-produced catalog products. For tillage applications this includes radial insert ball bearings and housing units, sealed deep groove ball bearings and

angular contact ball bearings, tapered roller bearings, bearings with hexagonal and square bores, as well as idler pulley units and roller chain idler sprocket units.

You can find out more in our “weighty” main catalog, HR1.



Comprehensive range of catalog products: More than 230 radial insert ball bearings and housing series are available from INA/FAG



Simply screw on and save: Crossed roller bearing for flange mounting with optimized space usage



Secure geometrical locking: This square housing unit is easy to mount on a shaft

Reliable and Economical: Components and Systems for Engines, Transmissions and Chassis



A broad range from one source: The majority of requirements for applications in the engine, transmission and chassis can be covered by brand components from INA, FAG, and LuK (Photo courtesy of AGCO Fendt)

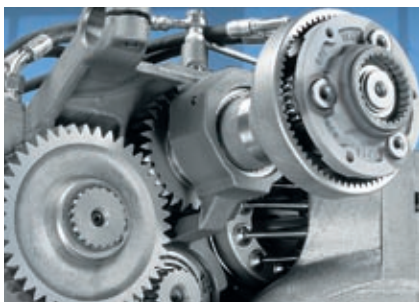

Robust solution: Compact roller bearing in planetary gearboxes

As a partner to the automotive industry for many years, the Schaeffler Group is an “insiders’ tip” for tractor manufacturers. Products from INA, FAG, and LuK are sophisticated in terms of technical characteristics and cost-effectiveness as well as extremely reliable in operation. This can lead to a decisive competitive advantage when considering the increasing work rates of modern tractors.



A wide variety of transmission bearings: Tapered roller bearings in X-life premium quality, e.g. for the axle drive – planet gear bearing support that can support extreme centrifugal forces – double row cylindrical roller bearing without outer ring for planetary gearboxes

Bearings and Assemblies for Transmissions

Based on the expertise of our Automotive division, we develop and manufacture transmission components for agricultural machinery under the INA and FAG brands.

Needle roller bearings, traditionally an INA specialty, are an important element in transmissions. The wide range includes formed bearings (drawn cup types) and machined (solid) bearings. With a full complement of needle rollers, these bearings are capable of supporting heavy loads in the smallest of spaces, and as needle roller and cage assemblies (cage with needle), they are lightweight and low friction.

Our range of roller bearings with or without cages is just as broad. Cylindrical roller bearings without outer rings are especially suitable for planetary gearboxes, since they can support both high radial and axial forces. The sophisticated range of FAG tapered roller bearings can cover a wide variety of bearing positions, for example in hydraulic motors and pumps that are integrated in the transmission, in pinion bearing supports or in rear axle drives.

Of course, we still offer our classic deep groove ball bearings, axial bearings, low-



Maintenance-free and capable of supporting high loads: ELGES rod ends and Permaglide® plain bushes for small swivel movements

wear synchro rings that are secured against rotation, high-precision fine blanked parts with complex geometries, shift detents with anti-corrosion protection, and much more.

Applications in the Chassis

Our range also includes spherical plain bearings, rod ends, and cylindrical plain bushes of the ELGES and Permaglide® brands. Spherical plain bearings with intelligent lubrication systems in the outer ring can be found, for example, in the connectors of sprung front axles to the chassis, and maintenance-free rod ends can be found in the steering systems of front axles with independent wheel suspension. Low-maintenance and maintenance-free cylindrical plain bushes are suitable for door hinges, engine hood bearing supports or also for lever systems.

Engine Components and Systems

Typical INA products for tractor engines are, for example, elements for belt drives such as tensioning systems and over-running alternator pulleys. Waterpump and fan bearings are just as much a part of this range as needle roller and cage assemblies for connecting rod bearing



As part of the Schaeffler Group and as a leading worldwide manufacturer of clutch and drive components, LuK is also renowned in agricultural engineering. Almost all major tractor manufacturers place their trust in the long operating life and impressive noise and vibration damping of LuK's clutch systems and torsional vibration dampers.

Picture on left: The "Safety PTO" double clutch – two clutches for driving opera-

tion and power take-off shaft in one component.

Picture on right: Arc spring damper consisting of a primary side that is bolted to the flywheel and a secondary side that is connected to the transmission input shaft. The bow springs have a large rotation angle and are very effective in eliminating transmission noise and vibrations from the drive train.

supports with cages with special profiles that are suitable for high accelerations.



Increase engine operating life: Crank pin cage for extreme accelerations and pulley for decoupling the generator from the rotational irregularities of the crankshaft

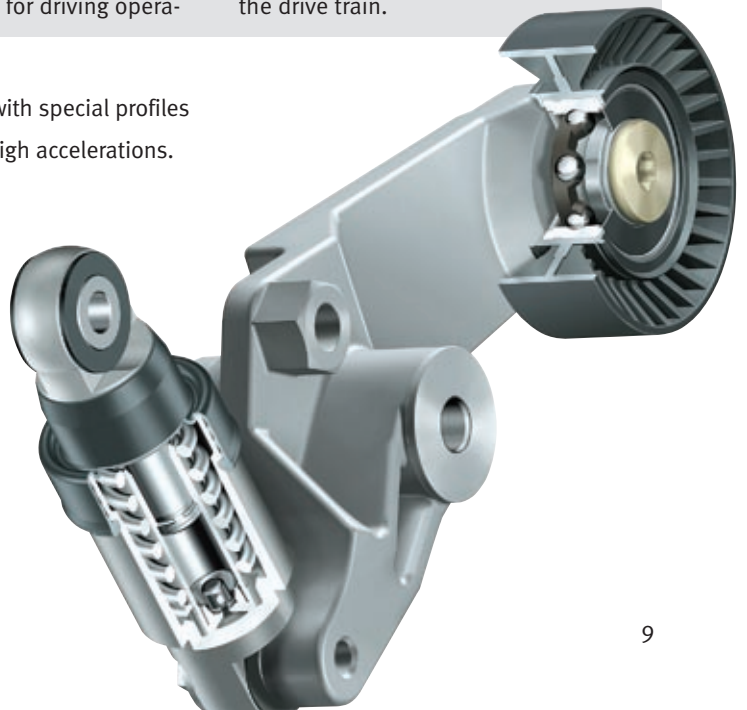

Effective Seals Are Essential: INA and FAG Rolling Bearings in Harvesting Machines



Increase the operating life of your machine! INA housing units offer high reliability due to their extremely effective seals (Photo: John Deere European Office)

Seals are used wherever rolling bearings turn in agricultural engineering applications. They have two important functions, namely retaining the high-quality grease in the bearing and preventing contamination and moisture from reaching the interior of the bearing. An effective seal increases the life of the bearing and therefore also the operating life of the agricultural machine.

Manufacturers of agricultural machines favor robust, secure and low-maintenance bearing solutions. The Schaeffler Group's high-performance seal concepts therefore secure a competitive advantage.

INA Radial Insert Ball Bearings: Proven Quality

INA is the leading manufacturer of radial insert ball bearings and housing units in Europe and South America. They are used in almost all sectors of industry. In agricultural engineering, they are used mainly in harvesting machines. These products are easy to mount and compensate non-aligned shafts at a defined swivel moment, which are decisive arguments for design engineers to use these products.

You will find over 230 series in the INA and FAG main catalog, HR1, for a diameter range of 10 to 120 mm. The modular concept of this range ensures you will find the perfect solution for every application.

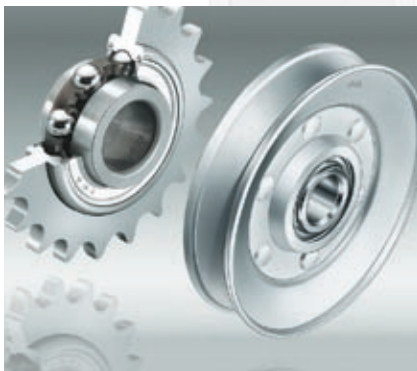

Roller chain idler sprocket unit/idler pulley unit for the drive of vibrating screens and elevator conveyors in combine harvesters



Flanged and plummer block housing units: These radial insert ball bearings are protected against corrosion with Corrotect®



For heavy loads: Spherical roller bearings can support axial forces in both directions and high radial forces

**Robust and Zinc-Plated:
Our Three-Piece Seal Concept**

The comprehensive range of standard seals for INA radial insert ball bearings has been developed over a period of many years and has proven itself on numerous occasions. In contrast to seals from other bearing manufacturers that are usually only one-piece seals, we prefer a system comprising three components – outer cap, rubber seal lip, and inner cap. The table below contains an overview of all the available variants.

Our range of seals covers nearly all operating and environmental conditions.

And the competitive advantages?

- A concentric seal contact surface means that the sealing action and operating life are considerably improved
- The seal lip is protected against mechanical damage by outer caps that extended well down the width of the sealing ring
- Zinc-plated inner and outer caps
- Rolled-in sheet steel seals for fixed seal seating enable easy relubrication, even with high grease pressure.



Baler in operation – an important application for INA track rollers (Photo courtesy of New Holland)

<p>P seals</p> <ul style="list-style-type: none"> • Two zinc-plated sheet steel washers with intermediate axially preloaded rubber lip • To protect the seal lip, the outer sheet steel washer extends a considerable distance down towards the bearing inner ring 	
<p>R seals</p> <ul style="list-style-type: none"> • Two zinc plated sheet steel washers extended outwards with an intermediate radially preloaded rubber lip • To protect the seal lip, the outer sheet steel washer extends a considerable distance down towards the bearing inner ring • Long relubrication intervals due to large grease reservoir 	
<p>R seals with flinger shield</p> <p>Similar to the R seal but:</p> <ul style="list-style-type: none"> • with an additional flinger type shield that is pressed on to protect the seal lip against mechanical damage and high-pressure cleaning 	
<p>T seals</p> <ul style="list-style-type: none"> • Two zinc-plated sheet steel washers with three intermediate radially preloaded seal lips for protection against extreme contamination • To protect the seal lip, the outer sheet steel washer extends a considerable distance down towards the bearing inner ring 	

Concept with advantages for the customer: The standard range of seals for INA radial insert ball bearings

From Bearing Supports for Variable Speed Mechanisms to Controlling Tine Arms: Economical Bearing Solutions with Technical Refinement



A new development: Adapter sleeve bearing support for high speeds and high shocks that is resistant to contamination

Fruitful partnership: We develop clever bearing solutions in close collaboration with manufacturers of agricultural machinery (Photo courtesy of New Holland)

Example 1: A Bearing Support for Variable Speed Mechanisms that can Withstand Extreme Shocks

This application places high demands on the bearing support. High bearing forces, extremely high speeds and an environment that is highly contaminated. INA has therefore developed a special bearing support for variable speed mechanisms. It consists of a radial insert ball bearing with optimized load carrying capacity and a shock-resistant housing made of spherical graphite cast iron with centering spigot which enables it to be easily fitted on the frame of the combine harvester.

The high speeds require concentric movement of the shaft, which is achieved by using an adapter sleeve. The flinger shields pressed onto the inner ring prevent the ingress of contamination into the bearing, which ensures the reliable operation of the variable speed mechanism.



High tilting rigidity and compact: INA four-point contact ball bearing in a shaker shaft of a combine harvester

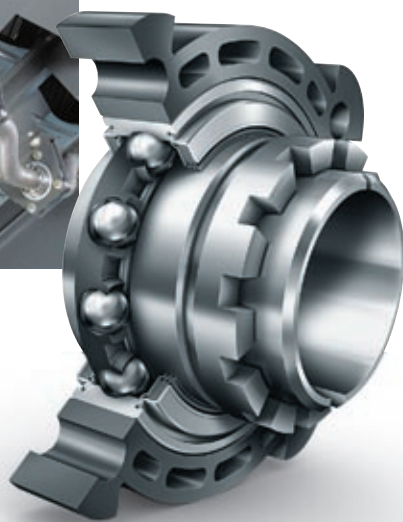

Example 2: Bearing Supports for Shakers with Effective Seals

The seals of bearing supports in shaker shafts are subject to extreme dust exposure especially in dry countries, for example during the soya harvest in Argentina. Here, the use of our proven three-lip seals is vital. The shaker plates must be guided very close to each other in order to achieve a high harvest yield. However, in order to prevent the plates coming into contact with each other, the bearing support must have high tilting rigidity. We have implemented this successfully by profile grinding the ring raceways (four point contact ball bearings) in the shape of a gothic arch. A lightweight plastic tire rounds off this economical system solution.

Example 3: Track Rollers that Generate an Economic Benefit in Tedding Machines

INA track rollers are used to control the tine arms in hay tedding machines. Each arm is controlled by a roller. Using these bearings generates a measurable economic benefit, since they are small, resistant to wear and reliable. They seldom require relubrication thanks to their large grease reservoirs and particu-



INA track rollers in tine arms ensure that tedding machines operate reliably and have a long operating life (Photo courtesy of FELLA-Werke)

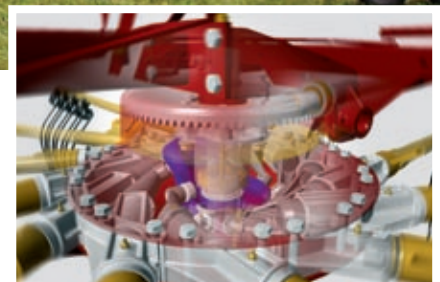

larly effective seals. The user benefits from reduced maintenance requirements and lower costs.

The technical superiority of INA track rollers compared with conventional components is due to the optimized outer raceway profile. The Hertzian pressure at the contact point is always lower than conventional track rollers – with or without tilting. This minimizes wear on the mating track, which has a positive influence on the operating life of the entire system.



Protect the mating track: Wear-resistant track rollers with optimized outer ring profile

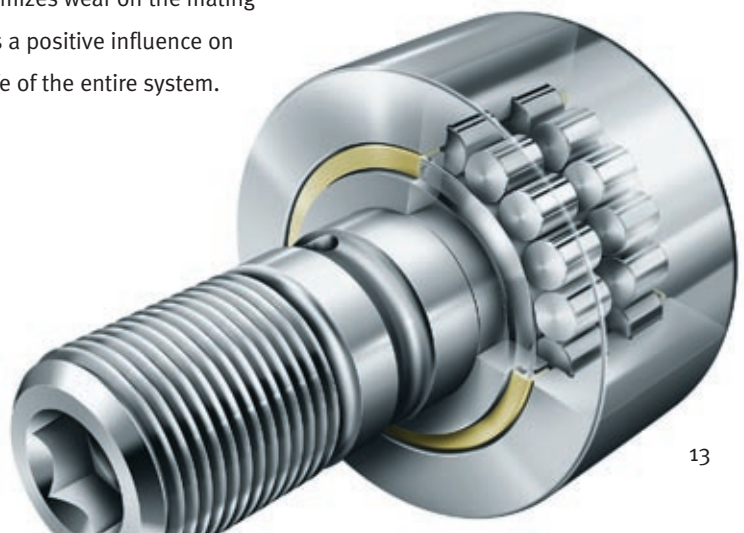

Comprehensive Service – In-depth Understanding of Agricultural Engineering

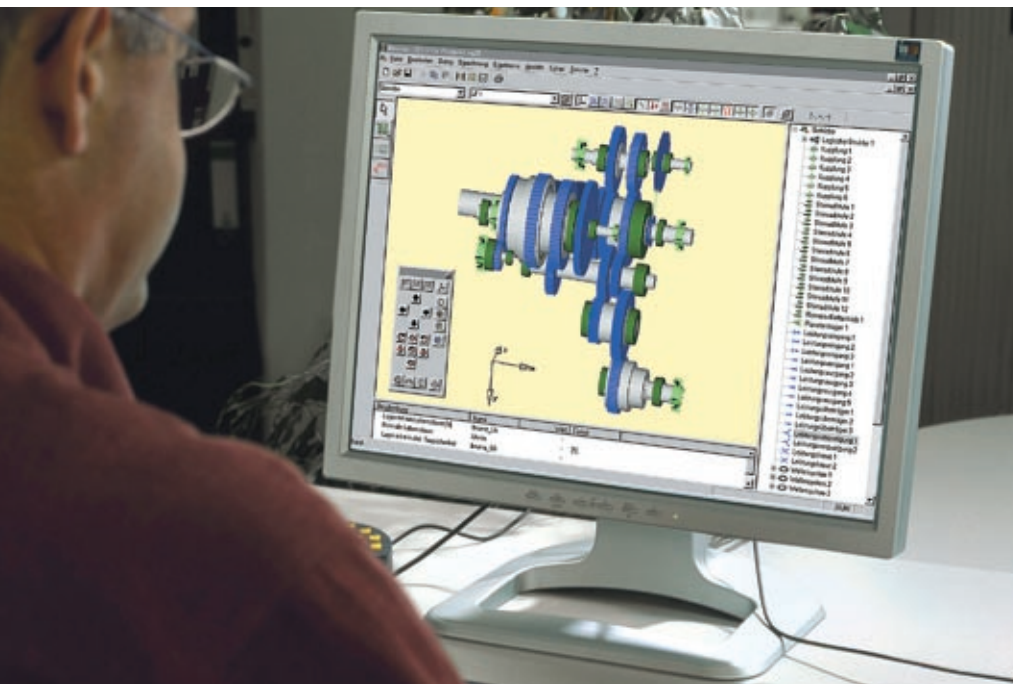

High operating safety – shorter development times: By using BEARINX® for bearing design, we can model actual operating conditions

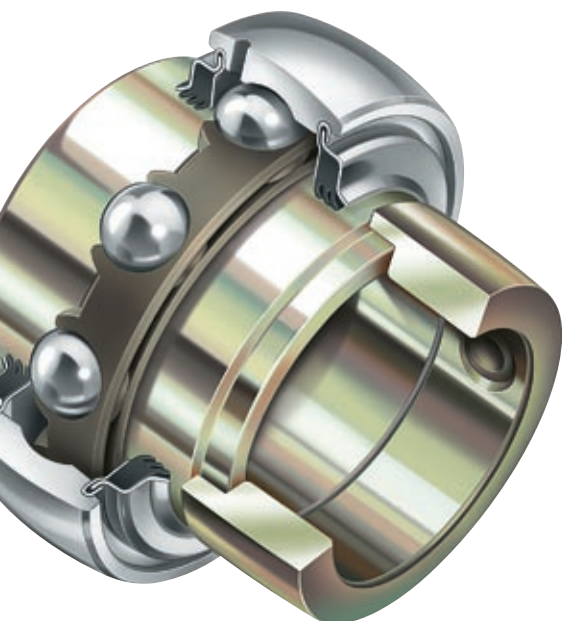

Extra protection against corrosion: Radial insert ball bearing with Corrotect® coating, an example of our range of surface coatings developed in-house

vester. This involves defining the gearbox elements, analyzing the load distribution and considering all operating conditions. For tasks like this, it is a good idea to consider seeking professional assistance from our engineering service for the design of the bearing supports. The program can emulate complex complete designs and can reproduce all the shifting positions in your gearbox. The load on every single bearing support can be depicted very precisely, calculated and then recorded. Manipulating the bearing position, shape or size will reveal performance reserves that quickly yield the most cost-effective solution.

Testing. We test our bearings on in-house seal test stands to ensure their suitability for various operating conditions.

Simulating a typical harsh agricultural environment is not a problem. If requested, customer samples are tested in all situations and for all functions in one of our R&D Centers – from wear behavior to noise.

Tribology. We thoroughly test the technical performance of all lubricants that we use for the initial greasing of our bearings. We recommend greases for agricultural applications that are particularly water-repellent or even have special resistance to the media involved.

And what can we do for you?

Good service is just as important for us as high product quality. This is why you can expect expert consultation from us, from the first design phase to bearing analyses on site and recommendations for lubricants, right up to using the test stands in the Schaeffler Group's R&D Centers.

Calculation. With BEARINX® we reduce the risk of incorrect bearing design in your machine. The program enables us to analyze all INA/FAG rolling bearing supports in detail. For example, you need to calculate a power take-off or a cut-length gearbox, for example for a forage har-



**Schaeffler Technologies
GmbH & Co. KG**

Industriestrasse 1 – 3
91074 Herzogenaurach (Germany)
Phone +49 9132 82-4412
E-Mail info@schaeffler.com
Internet www.ina.com

FAG

**Schaeffler Technologies
GmbH & Co. KG**

Georg-Schäfer-Strasse 30
97421 Schweinfurt (Germany)
Phone +49 9721 91-1609
E-Mail FAGinfo@schaeffler.com
Internet www.fag.com

Every care has been taken to ensure the correctness of the information contained in this publication but no liability can be accepted for any errors or omissions.

We reserve the right to make technical changes.

© Schaeffler Technologies GmbH & Co. KG
Issued: 2010, June

This publication or parts thereof may not be reproduced without our permission.